

Goods Code: 001552

### Features

- ◆ 32-bit DSP-based digital control
- ◆ Low vibration, low noise, and low power consumption
- ◆ Maximum output current 4A/phase
- ◆ CAN bus is used; it supports standard CANopen communication protocol and can maximally drive 127 devices
- ◆ It supports profile position control mode, speed control mode and cyclic position mode
- ◆ Current and segmenting configuration, motor start/stop control and real-time monitoring of motor running status can be achieved through the bus
- ◆ 3 channels of optoelectronic-isolator programmable input interface are used



**【Note】 This manual is only for standard products, so it doesn't cover the custom-made products developed as per customers' demand.**

### Performance Index

#### Electrical performance (environmental temperature $T_j=25^{\circ}\text{C}$ )

|                                    |   |
|------------------------------------|---|
| Power supply                       | 24V ~50VDC, capacity 0.2KVA   |
| Output current                     | Peak value 4A/phase, (max.) current value can be set                |
| Drive method                       | Spatial vector bipole constant-current drive                        |
| Excitation method (steps/rotation) | 200, 400, 800, 1600, 3200, 6400, 12800, 25600                       |
| Insulation resistance              | > 100MΩ (at a normal temperature and normal atmospheric pressure)   |
| Insulating strength                | 1KV, 1Min (at a normal temperature and normal atmospheric pressure) |

#### Environment of Use and Parameters

|                     |   |  |
|---------------------|---|--|
| Cooling method      | Natural convection (installation of the driver onto a metal surface with good heat conduction can improve heat dissipation) |  |
| Service environment | Precaution  | Dust, oil mist and erosive gases shall be removed as much as possible. |
|                     | Temperature   | $-5^{\circ}\text{C} \sim +40^{\circ}\text{C}$                          |
|                     | Humidity  | < 80%RH, without condensation and frost formation                      |
| Storage environment | Vibration   | $5.9\text{m/s}^2$ Max  |
|                     | Temperature   | $-40^{\circ}\text{C} \sim +55^{\circ}\text{C}$                         |
| External dimensions | Humidity  | < 93%RH, without condensation and frost formation                      |
|                     | Weight  | 135×77×26mm  |
|                     |   | 0.2Kg  |

**【Note】** As abrupt temperature change of the storage or transport environment is very likely to cause condensation or frosting, in such case, the driver shall be kept unused for over 12 hours to let its temperature rise to roughly the same level of environment temperature, then its power can be turned on for operation.

## Functions and Use

### ◆ Outstanding Features

Based on fully digital control with a 32-bit DSP as its kernel, and an advanced spatial vector algorithm to optimize low-speed vibration and high-speed performance, the product is adaptive to multiple types of motors and can achieve the optimal control method. Its software upgrade is very convenient.

The CAN bus used in it supports standard CANopen communication protocol, and can maximally be loaded with 127 devices. It supports profile position control mode, speed control mode and cyclic position control mode.

Through bus communication, the user can not only read the driver's running status, and change the parameter configuration, but also achieve control of the stepping motor's speed and position (by using either absolute position commands or relative position commands) under bus mode, which makes networked application very convenient.

Low vibration, low noise and low power consumption.

### ◆ Power Supply

The driver's internal switch-mode power supply ensures adaptability to a wide voltage range, so the user can select a power supply voltage value between 24V and 50V DC depending on his actual condition; the power supply's capacity is related to the motor to be matched and the set value of current. In general, a high rated power supply voltage is good for raising the motor's high-speed torque, but will increase the driver's wastage and temperature rise. **Pay attention to power supply polarity to avoid reverse connection.**

### ◆ Debugging Mode Switch

By using the No.5 DIP switch on the operation panel, the user can enable or disable debugging mode. To enable it, the user has to set SW5=ON before the driver's power is turned on, after the enabling, the driver will always enter debugging mode when its power is turned on, then, if the user sets SW5=OFF, the motor will rotate at 200RPM, if the user then sets SW5=ON again, the motor will stop rotation. When debugging mode is disabled (namely SW5=OFF before the driver's power is turned on), the driver will enter normal working mode. So change of SW5's status could take effect only after the driver's power is reswitched on.

### ◆ Setting of Communication Baud Rate

The driver employs 2 methods to set the bus communication baud rate:

Method 1: SW6=OFF (to be set through DIP switch), baud rate=250Kbit/s;

Method 2: SW6=ON (to be set through communication), a value (range: 20-1000, under Sub-index 4, Object Index 2000) can be set through SDO; the baud rate values supported are 20K/50K/100K/125K/250K/500K/1000K bit/S.

**Note: the user's change of communication baud rate value can take effect only after the driver is reswitched on.**

### ◆ Setting of Communication Station Address

The driver employs 2 methods to set its communication station address:

Method 1: SW6=OFF (to be set through DIP switch), the station address (range: 1-4) is determined by SW1-SW2; in such case, setting of station address through communication is ineffective, and the station address=  $SW1+SW2*2+1$ , in which SWN=ON means the SWN's value is 1, and SWN=OFF means its value is 0.

Example

| Station Address | SW1 | SW2 | SW6 |
|-----------------|-----|-----|-----|
| 1               | OFF | OFF | OFF |
| 4               | ON  | ON  | OFF |

Method 2: SW6=ON (to be set through communication), a value (range: 1-127, under Sub-index 3, Object Index 2000) can be set through SDO.

**Note: the user's change of communication station address can take effect only after the driver is reswitched on.**

### ◆ Setting of Normal Working Modes

For normal working, the DIP switch SW5=OFF, in which case the driver supports 3 normal working modes (details of which are in CANopen communication manual):

- (1) Speed communication mode (set Object 6060=FDh)

Under this mode, the motor can move as per the designated speed and time length for acceleration and deceleration.

- (2) Cyclic position mode (set Object 6060=8h)

Under this mode, the upper device cyclically sends position commands to control the stepping motor's position. The diagram below is the stepping motor's speed-time curve.

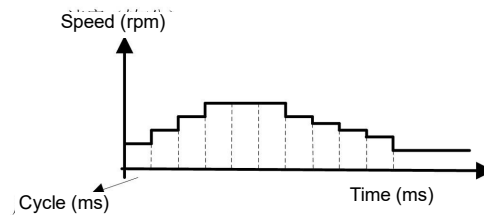

- (3) Profile Position Mode (set Object 6060=1h)

Under this mode, the upper device sends (relative or absolute) position commands, and the driver automatically moves to the designated position as per the parameter setting, specifically as per the given speed and acceleration/deceleration time.

The figure below is the stepping motor's speed-time curve:

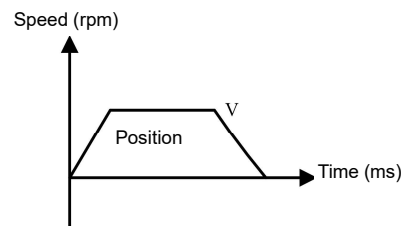

◆ **Automatic Halving of Current**

If the motor's speed keeps at 0 when the driver has worked continuously for 0.1s, the driver will automatically reduce its phase current value to 50% of the standard value to reduce power consumption. When the motor speed isn't 0, the driver will automatically exit from the half-current status.

◆ **Overvoltage Protection**







When power supply voltage fluctuation, or motor braking, or any other event causes the DC link voltage to exceed 60VDC, the driver's overvoltage protection circuit will act, the driver's alarm light (red) will flash, and the driver will temporarily stop driving the motor. The alarm can be cleared only by manually reswitching on the driver. In case of such fault, the user needs to check power supply voltage and appropriately reduce the input power supply voltage.

◆ **Undervoltage Protection**

When the driver detects the DC link's input voltage is lower than 20VDC, its undervoltage protection circuit will act, and the driver's alarm light (red) will flash, and the driver will cut motor winding output to stop motor running. The alarm can be cleared only by manually reswitching on the driver. In case of such fault, the user needs to check power supply voltage and capacity, and appropriately increase input power supply voltage.

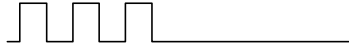
◆ **Function Status Indication**

The yellow LED is power supply indicator light, which is always on when the driver is already turned on; when the driver is turned off, this indicator light turns off. The red LED is fault indicator light, which will turn on and off in different ways in case of fault. Different ways of the red LED's turning on and off represent different fault information. The table below shows the concrete relationships between such ways and the fault information.

| Way of Red Light's Flashing         | Wavefrom of Red Light's Flashing  | Fault Description   |
|-------------------------------------|---|---|
| Always on                           |  | Overcurrent alarm   |
| Flashing twice every other second   |  | Wrong AD sampling middle point  |
| Flashing 3 times every other second |  | Motor wires are not connected, or motor wires' contact is poor, or motor windings are short-circuited |
| Flashing 4 times every other second |  | Undervoltage (voltage<20V )   |
| Flashing 5 times every other second |  | Overvoltage (voltage>60V )  |
| Flashing 6 times every other second |  | E2PROM fault  |

**Control Signals**

The connecting terminals for the driver are plug-type; they can be pulled off first and then be plugged in after it's been connected to wires. The input control signals are transmitted through two-terminal ports, which can be connected in multiple patterns like common-anode, common-cathode, and differential pattern.

**Input 1 Signal** The driver's ports have in-built optocouplers. In order to ensure reliable response to the input signals, the effective on-time of optocouplers shall not be shorter than  $2\mu\text{s}$ . An internal resistor ( $330\Omega$ ) is connected in series with the port, enabling the port to adapt to TTL signals. When the signal voltage is higher, please consider series connection of a current-limiting resistor ( $1\text{k}\Omega$  for 12V signal voltage,  $2\text{k}\Omega$  for 24V signal voltage).

**Input 2 Signal** The driver's ports have in-built optocouplers. In order to ensure reliable response to the input signals, the effective on-time of optocouplers shall not be shorter than  $2\mu\text{s}$ . The ports can adapt to TTL, OC, differential and other formats of signal, and a voltage of  $3\text{V}\sim 24\text{V}$ .

**Input 3 Signal** The driver's ports have in-built optocouplers. In order to ensure reliable response to the input signals, the effective on-time of optocouplers shall not be shorter than  $2\mu\text{s}$ . The ports are adaptive to TTL, OC, differential and other formats of signal, and a voltage range of  $3\text{V}\sim 24\text{V}$ .

**Typical Wiring Diagram**

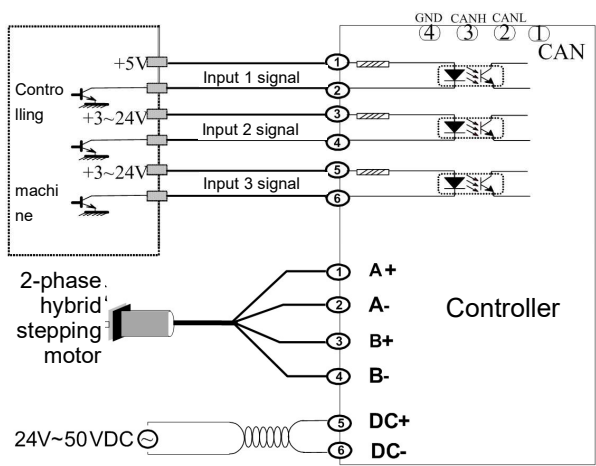

**Note:**

To better utilize the driver, the user should separate power wires (motor phase wires, power supply lines) in wiring layout from weak current signal wires to avoid interference to control signals. If such separation is impossible, or there's any strong interference source (frequency converter, solenoid valve, etc.), it's better to use shielded cables for control signals; use of relatively high levels for control signals can also to a certain degree improve resistance to interference.

**Input Port Circuit**

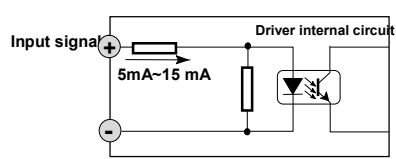

**External Size [Unit: mm]**

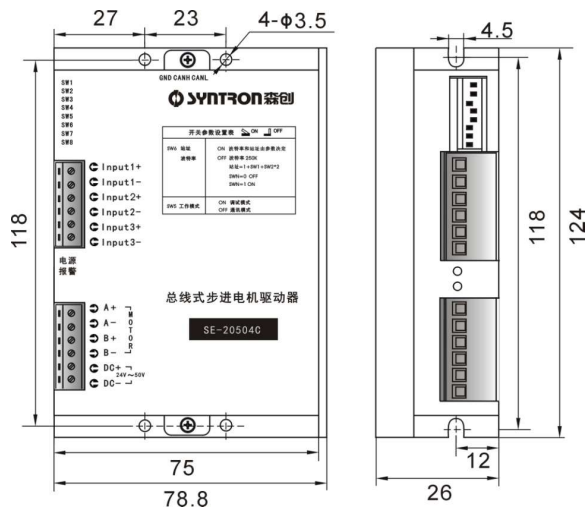

**Note:**

Product customization can be provided as demanded by customers. The model code ending with Ver \*.\* is a special custom-designed one (\*.\* is the version No. of the custom design).



Manufacturer: Beijing HollySys Electric Technology Co., Ltd.  
(formerly Stone Motor)

Add: 10th Floor, Block A, Huizhi Mansion, 9 Xueqing Road,  
Haidian District, Beijing

Postal Add: Postbox 2877, Beijing, 100085

Central exchange: (010) 62932100

Extensions: sales—100; technology support—810

Sales hotline: (010) 62927938

Fax: (010) 62927946

Website: www.syn-tron.com

Nanjing office: (025) 84293632/37/52/53

Shenzhen branch: (0755) 26581960/61/62

©1707 by Hollysys Electric 07/2017

The information in the  
manual may be changed  
without prior notice